

Specification Sheet

C700 Positive Displacement Meter Polymer, Magnetic Drive, External Threaded Spuds



Size: 5/8" x 1/2", 5/8" x 3/4", 3/4" x 3/4" and 3/4" x 1"

Description

Operation. The C700 polymer meter is a positive displacement type meter operating on the oscillating piston principle. The product utilizes a piston that water use rotates in a measuring chamber, each piston revolution being equivalent to a known volume of water. The piston movement is transferred by magnetic drive to a straight reading sealed register which contains the appropriate reduction gearing.

Compliance to Standards/Approvals. The C700 polymer meter complies with all performance and material requirements of the American Water Works Association Standard C710 as most recently revised. The C700 polymer meter is NSF-61 Certified, complies with California Proposition 65 lead free requirements, and is California Department of Weights and Measures approved.

Installation. The meter must be installed in a clean pipe line, free from any foreign materials. Install the meter with direction of flow as indicated by the arrow molded in the meter case. The meter may be installed in horizontal or inclined lines.

Application. *The meter is for use in POTABLE COLD WATER up to 120°F (50°C) and working pressures up to 150 psi.* The meter will perform with accuracy registration of 100% ± 1½% within the normal flows. Both pressure loss and accuracy tests are made before shipment. No adjustments need to be made before installation.

Other Applications. Deionized (DI) or reverse-osmosis (RO) water, water glycol solution (over 50% water), sodium hydroxide (20% solution), pool water (city water with bleach), and salt water.

Construction. The meter consists of a main case, an oscillating piston measuring chamber, a polymer strainer, a removable top plate and O-ring, and a magnetically driven register assembly. The main case is molded in plastic with raised characters show-

Specifications

Sizes:	5/8" x 1/2"	5/8" x 3/4"	3/4" x 3/4" 3/4" x 1"
95% -101% Accuracy GPM	1/4	1/4	1/2
98.5%-101.5% Accuracy GPM	1-20	1-20	2-30
Continuous Flow GPM	15	15	15
Maximum Flow GPM	20	20	30
Operating Pressure psi	150	150	150
Operating Temperature °F	120*	120	120
	*(67°C)		
<u>Sweep Hand Registers:</u>			
US Gallons	10	10	10
Cubic Feet	1	1	1
Cubic Meters	1/10	1/10	1/10
Imperial Gallons	10	10	10
<u>Capacity of Register</u>			
US Gallons (millions)	10	10	10
Cubic Feet (millions)	1	1	1
Cubic Meters (millions)	1/10	1/10	1/10
Imperial Gallons (millions)	10	10	10
<u>Register Type</u>	Permanently sealed direct reading register		
<u>Materials</u>			
Main Case	Modified Acetal Copolymer		
Top Plate	Modified Acetal Copolymer		
Body O-ring	Neoprene Rubber		
Measuring Chamber	Compounded Thermoplastic		
Thrust Bearing Insert	Loaded Nylon		
Piston	High Impact Polymer		
Division Plate	Loaded Nylon		
Driving Bar	Loaded Nylon		
Strainer	Polypropylene		
Register Can	90% Copper Alloy		
Domed Register Lens	Tempered Glass		
Register Housing & Lid	Polymer		

ing model, size, and direction of flow. The measuring assembly is a top-in and a bottom-out design and consists of the measuring chamber with division plate, drive bar, magnet and a locator pin. The measuring chamber is held against its seat by the top plate. The threaded main case and top plate are assembled with an O-ring gasket. Each register assembly is secured to the maincase with a slotted head screw, is protected with a hinged lid and is positioned with its hinge over the inlet throat. The register can may be rotated and locked in any 360 degree position therein.

Connections. Meter casing spuds have external straight threads conforming to ANSI B2.1 Bronze or polymer coupling nuts and tailpieces are available. Both coupling nuts and tailpieces have external taper pipe threads conforming to ANSI B2.1 Their lengths and thread sizes are as specified by AWWA Standards.

Maintenance. The measuring chamber assembly can be removed, repaired or replaced without removing the main case from the service line. Pretested measuring chamber assemblies are available for exchange or purchase, and spare parts are available from our central warehouse or designated regional locations. AMCO Water Metering Systems staffs and operates a repair facility at its U.S. manufacturing plant in Ocala, Florida.

5/8":



3/4":



Direct Read Register. The magnetically driven register is contained within a 90% copper seamless can which is oven-cured at 150°F for 90 minutes to eliminate condensation. The 1/4" true tempered glass lens is domed and secured in an "L" shaped gasket. To assure easy reading, the totalizer wheels are large and color coded. The applicable size, model, registration, part number and date code are printed on the calibrated dial face. Moving clockwise during operation, the extra thin center sweep hand does not interfere with meter reading and the 1:1 ratio low-flow indicator will detect plumbing leaks.

Pulsar Type "B". Limit switch, 2 wire, 1 contact = 1 USG all sizes. This unit requires power from an external source. The pulser can be set up as a normally open contact or a normally closed contact. Please specify on order entry. The "B" pulser provides a contact closure from a limit switch with a max rating of 3 amps at 125 VAC. The unit does not provide a remote counter. The pulser is suitable for use with remote counters, batch controllers, rate transmitters or direct to computer or other device accepting contact closures. Note: Register housing and register are 3 1/2 in. diameter style. Specification sheet is available, #INDC7-PUL-001.

Pulsar Type "SF". Solid state, 3 wire. This unit requires 6-24 VDC from an external source. The "SF" pulser adds a high frequency output capability to the standard C-700 register (retains register readability). The output is an open collector current sink (NPN) (20 mA max.) magnetically actuated to provide a 50/50 open/closed ratio. Supply voltage 6-24 VDC; supply current 13.5 mA (max.). The unit is rated NEMA 4 for water and dust protection. Note: Register housing and register are 3 1/2 in. diameter style. For contact closure information, see specification sheet #INDC7-PUL-001.

Dimensions and Net Weights

Meter Size	Dimension (inches)					Weight (lbs.)
	A	B	C	D	E	
5/8" x 1/2"	7 1/2	5 3/8	1 3/8	4 3/4	9 3/8	3 1/4
5/8" x 3/4"	7 1/2	5 3/8	1 3/8	4 3/4	9 3/8	3 1/4
3/4" x 3/4"	9	5 15/16	1 15/16	5	9 15/16	3 5/8
3/4" x 1"	9	5 15/16	1 15/16	5	9 15/16	4

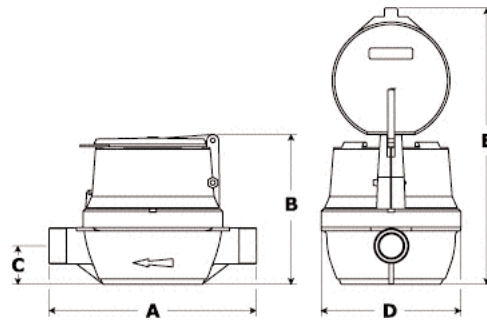

AMCO Water Metering Systems Inc.

www.amcowater.com

United States - ISO 9002 Registered
 AMCO Water Metering Systems
 P. O. Box 1852
 Ocala, FL 34478-1852
 352-732-4670 FAX 352-368-1950
 Outside Florida: 800-874-0890
 Inside Florida: 800-356-6829
 e-mail:
 watermeters@amcowater.com

Canada
 Elster Metering
 3450 Harvester Road
 Burlington, Ontario L7N 3W5
 866-703-7582
 905-634-4895
 FAX 905-634-6705
 e-mail:
 watermeters@ca.elster.com

Caribbean
 AMCO Water Metering Systems
 P. O. Box 225
 Carretera 112 KM 2.3
 Isabela, PR 00662
 787-872-2006
 FAX 787-872-5427
 e-mail:
 prwatermeters@amcowater.com

Mexico
 Elster Medidores
 Lago Omega #281
 Col. Modelo Pensil.
 Del. Miguel Hidalgo
 C P 11460
 525 55 203 8002
 FAX 525 55 203 8270
 e-mail:
 amcowater@prodigy.net.mx

The company's policy is one of continuous product improvement and the right is reserved to modify the specifications contained herein without notice.

© 2003 AMCO Water Metering Systems Inc. All rights reserved.

IND-C700PL-5834/02-03